

KGS 218



• Specifications

Application	Domestic & Industrial, Low current
Detection Method	Catalytic
Gases Detected	Most Combustible Gases
Range	0 ~ 100%LEL
Rated Voltage	2.5Vdc
Current Consumption	180±20mA
Zero Offset Voltage	-55 ~40mV(23±2°C, 60%RH)
Output Sensitivity	27±5mV/%methane
Linear to	3%methane
T90 Response Time	Within 10 secs(methane)
Long Term Sensitivity Drift	<3%signal/month
Long Term Zero Drift	<1%LEL(methane)/month
Warranty Period	2 year from date of despatch

* Flow rate of 300mls/min. Conditions at 23±2°C, 60%RH, and 1 atm unless otherwise noted.

• Relative Sensitivity

Gas	Relative Sensitivity
Detection Method	Catalytic
Methane	100
Propane	70
iso-butane	65
Pentane	60

* The results are intended for guidance only at the same %LEL concentration.

• Basic Measuring Circuit

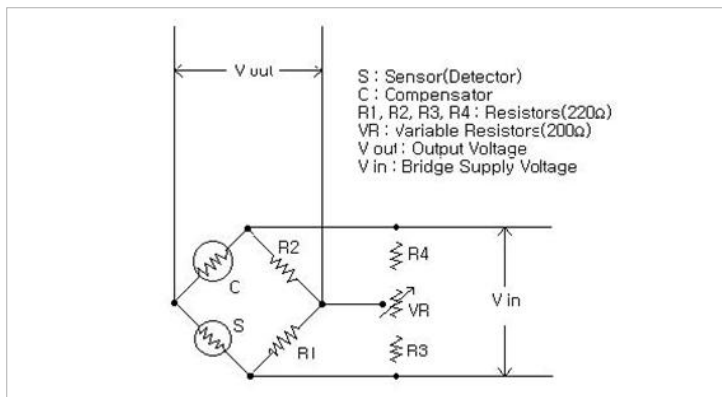

• Structure and Materials

